

**STEELMATE**  
*Automotive*

PTS400EX-F

*Parking assist system*



*Think safety think Steelmate*



**STEELMATE CO., LTD.**  
[www.steel-mate.com](http://www.steel-mate.com)

All rights reserved  
The trademark, patent and copyright are owned by Steelmate Co., Ltd.  
The right to change the design and specifications reserved



Manual

### User's Manual

Important notice -----	1
Disclaimer-----	1
About the product-----	2
Key features-----	2
Technical specifications-----	2
Buzzer & Display(optional)-----	3
self-test function -----	3
Learning function -----	4
Automatic car mute function -----	4
2/4-sensor automatic recognition -----	4
How does the system work-----	5
Attention-----	7
Sensor maintenance -----	7

### Installation Manual

Brief installation diagram-----	9
Packing list-----	10
Installation tools-----	10
Sensor installation-----	11
Buzzer installation-----	15
Function test after installation-----	16
Installation diagram-----	17
Troubleshooting-----	20
Warranty terms-----	20
Warranty card-----	21

## Parking Assist System User's Manual

## Important notice

Parking assist systems help to provide assistance when reversing and parking. Driving skills, such as slowing down, use of mirrors etc. is always essential.

1. This unit is for vehicles with 12V DC only.
2. Unit should be installed by a professional auto technician.
3. Route wiring harness away from heat sources and electrical components.
4. It is strongly recommended to check the position of the sensors before the actual drilling of the holes.
5. Perform test after finishing the installation.

## Disclaimer

The parking assist system is designed as a driver assistance device, and should not be used as a substitute for safe parking practices. The area into which the vehicle is driving or to be reversed must be constantly visually monitored while parking.

The manufacturer and its distributors do not guarantee or assume liability for collisions or damages while parking your vehicle.

## About the product

Parking assist system is an ultrasonic distance monitoring system. It electronically detects the area in front of your vehicle while parking, and alerts you with audible tones if the system detects an obstacle. The system will show the accurate distance in meters or feet (upgrade to LED/LCD display).

This product is 4-sensor systems for front bumper protection. They can also work as 2-sensor systems. Combined with functions such as automatic audio mute, self-test and learning function, they are ideal for cars with front metal bar.

This product can upgrade to displays, The modern display can be easy to install on the dashboard or on top of the rear-view mirror.

Each part of this product has passed the most stringent test before releasing to the market. It is reliable at a wide temperature range (-40°C/-40°F ~ +85°C/185°F) and becomes very useful when you are parking in poor weather conditions.

With the help of our parking assist system, you can enjoy a convenient and easy parking experience.

## Key features

- 1 4 front sensor system
- 1 Buzzer can be upgraded to LED/LCD displays
- 1 Can also work as a 2-sensor system
- 1 Compatible with front metal bar
- 1 Automatic car audio mute function
- 1 Self-test function
- 1 Anti-false alert technology
- 1 All weather design(-40°C/-40°F ~ +85°C/185°F)

## Technical specifications

- |                               |                                 |
|-------------------------------|---------------------------------|
| 1 Input voltage:              | 9~16V DC                        |
| 1 Operating current:          | <250mA                          |
| 1 Sensor installation height: | 45~60cm                         |
| 1 Detection range:            | 0.3m/1.0ft~0.9m/2.9ft           |
| 1 Operating temperature:      | -40°C ~ +85°C<br>-40°F ~ +185°F |
| 1 Buzzer SPL:                 | 70~90dB                         |

## Buzzer & Display (optional)

The alert buzzer can be upgraded to display. These pictures are for reference only, the actual display may vary.

Only some displays have set button or digital indication. Digital indicator and volume adjustable function depend on the display you choose.

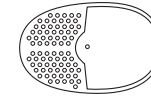

Buzzer

LED display (optional)



LCD display (optional)



## Self-test function

1. All sensors are working normally

No beep



2. Damaged sensor is detected

Be...Be...Be...



- Beep three times.
- Other sensors keep working.

## Learning function

Turn ignition on, press footbrake and connect the green learning wire to a +12V power supply (i.e. pink wire in the fuse connector). The system will perform learning procedure.

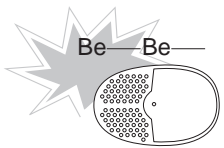

The buzzer will give 2 audible tones. This indicates that the learning function is successful and the system will ignore the front protrusion. Then disconnect the green wire and insulate it.

Note: if the vehicle does not have front metal bar or other front protrusion, the above procedure is not needed.

## Automatic car audio mute function

When reverse gear is engaged, the system will automatically mute the car audio.

This function aims to help the driver to reverse safely without distraction.

## 2 / 4-sensor automatic recognition

This 4-sensor system can be used as a 2-sensor system.

This has to be done by connecting the 2 central sensors (F&G) or 2 outside sensors (E&H).

## How does the system work

Driving forward, press footbrake

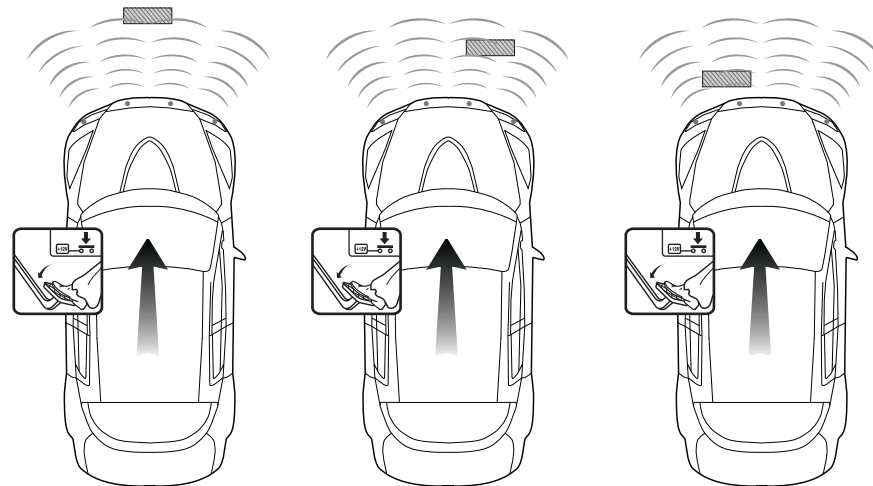

No beep



Distance: 0.9m/3.0ft

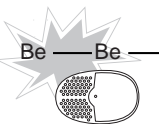

Distance: 0.5m/1.5ft

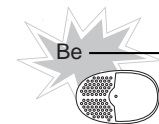

Distance: <0.3m/1ft

## Reversing

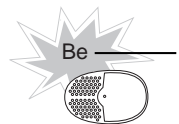
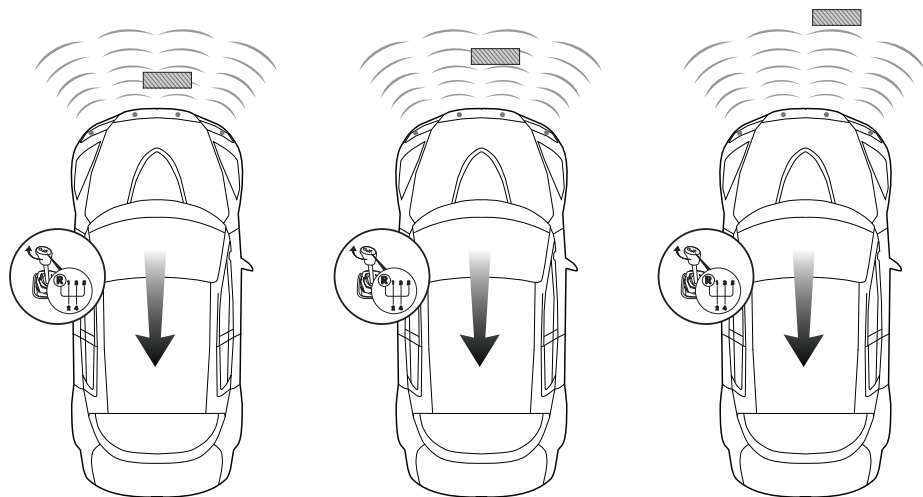

Distance:  $< 0.3\text{m}/1\text{ft}$

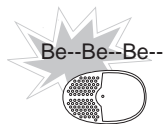

Distance:  $0.5\text{m}/1.5\text{ft}$

No beep



Distance:  $0.7\text{m}/2.3\text{ft}$

## Attention

False detection may occur in the following situations:

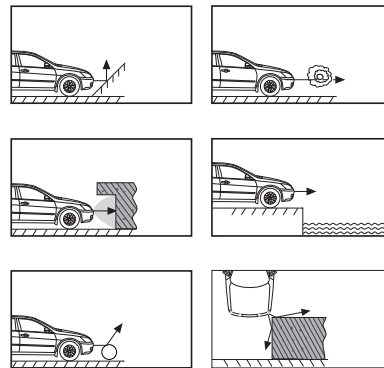

- 1 After installation, please fully test the system before use.
- 1 Heavy rain, dirty or damaged sensors may result in false alarm occasionally.
- 1 Ensure that the self-test procedure is completed and all sensors are functioning before using the system.

## Sensor maintenance

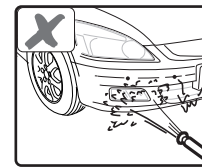

Do not wash the sensor with a pressure washer or scrub them forcibly.

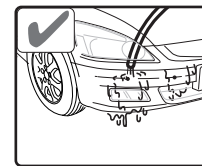

Please wash car with low-pressure water.

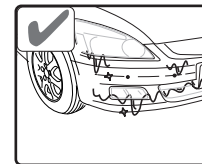

Please melt the ice with warm water when the sensors are covered by ice.

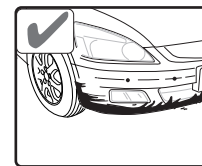

Please clean the sensors with cloth or low-pressure water when the sensors are covered by dirt or snow.

Parking Assist  
System  
Installation Manual

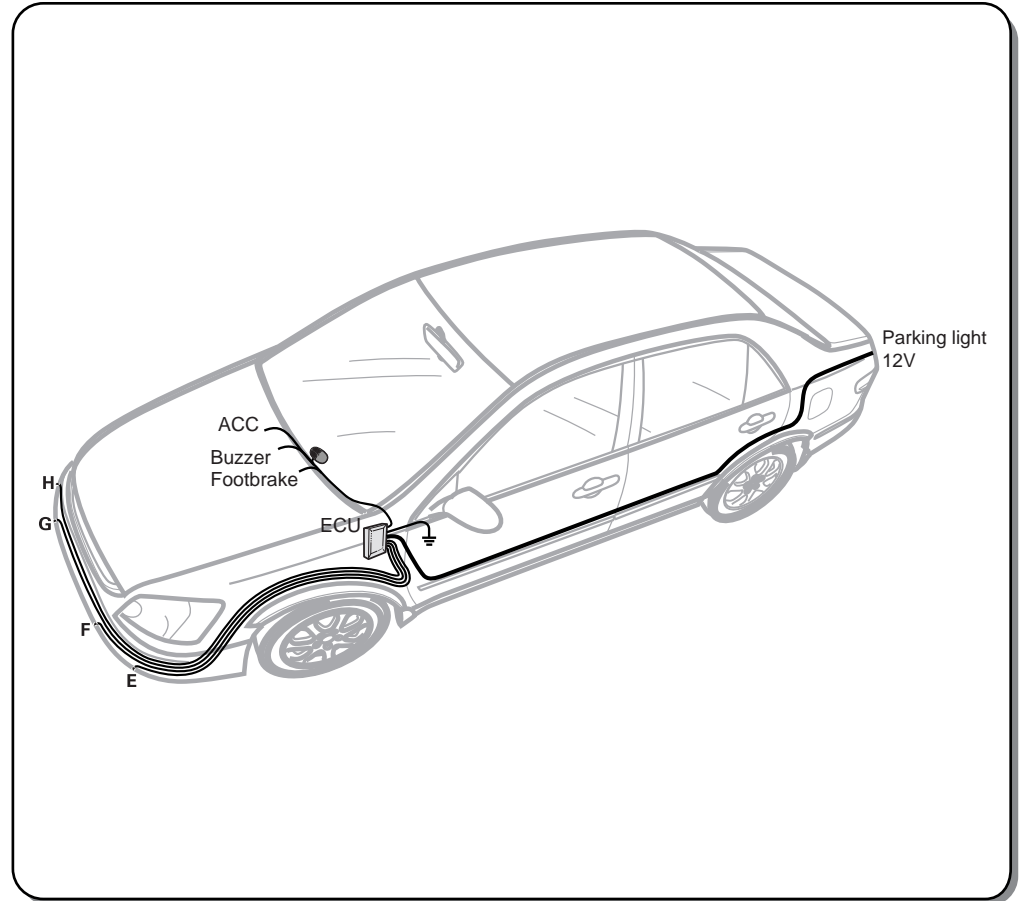

## Packing list

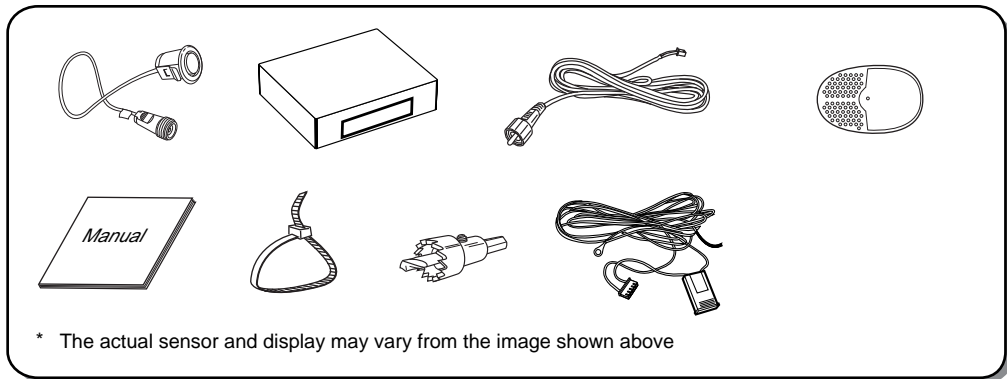

## Installation tools

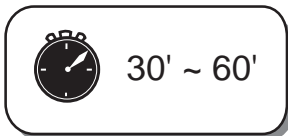
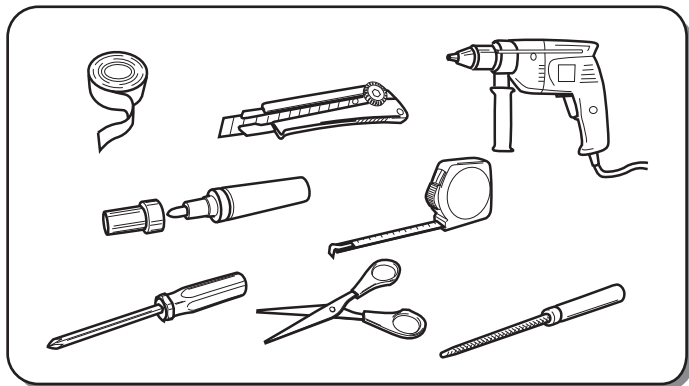

## Sensor installation

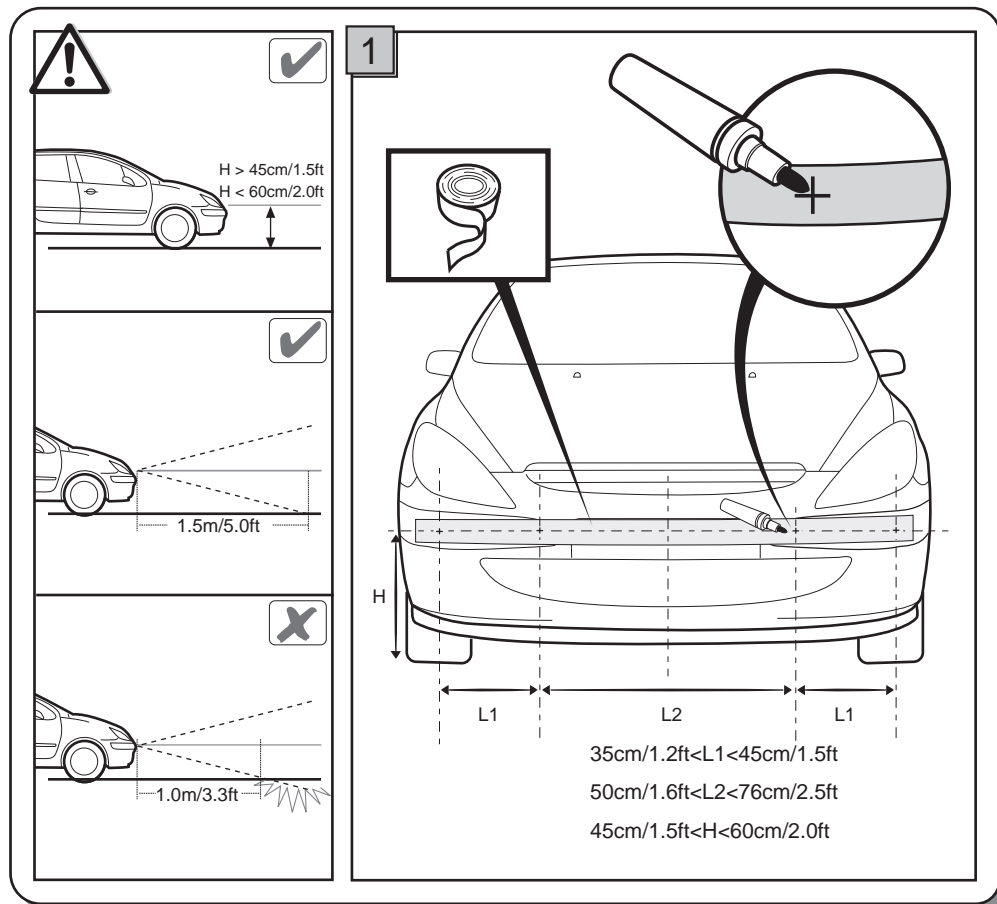

2

Check the size of the hole saw packed in the product matches the diameter of the sensors before drilling any holes.

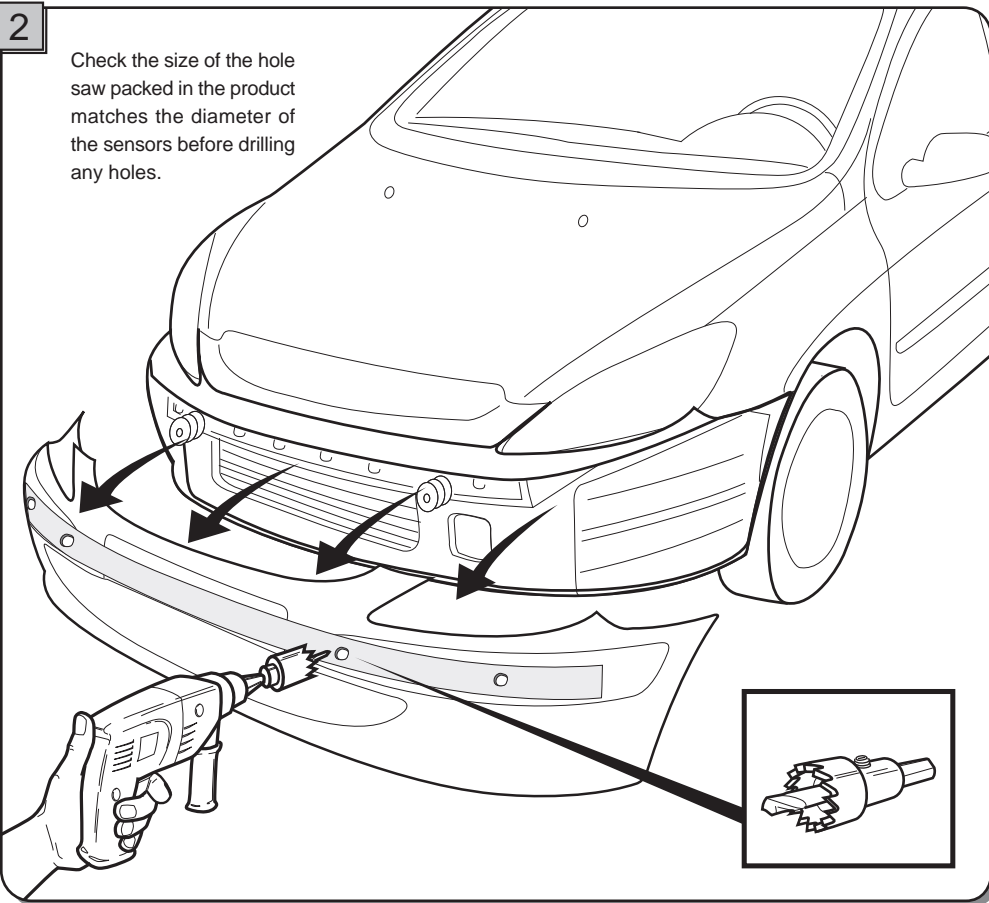

3

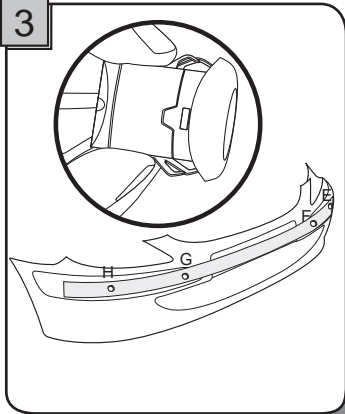

4

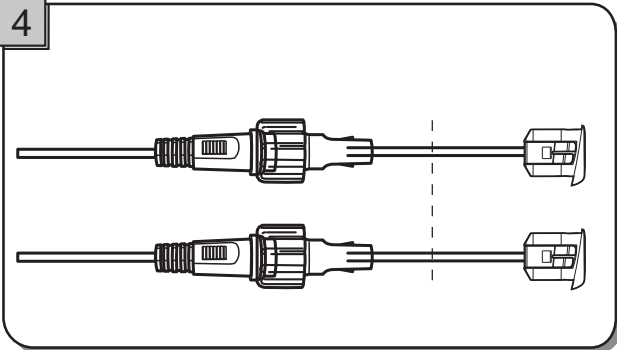

5

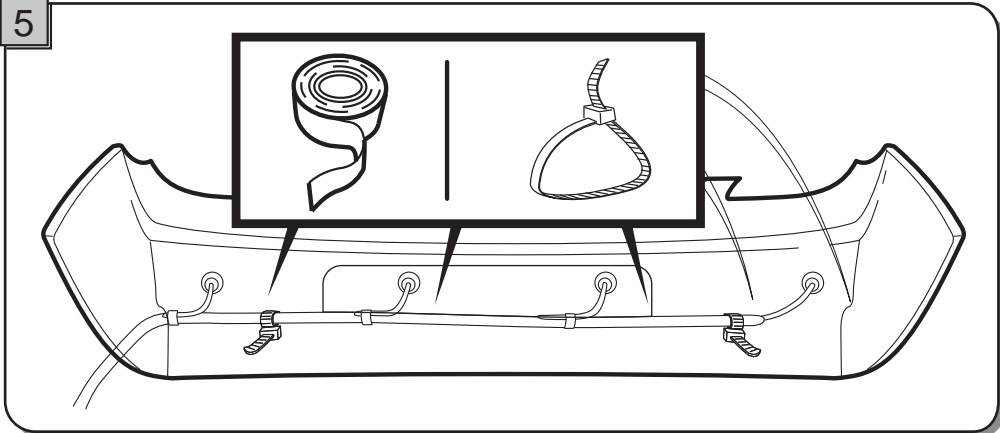



6

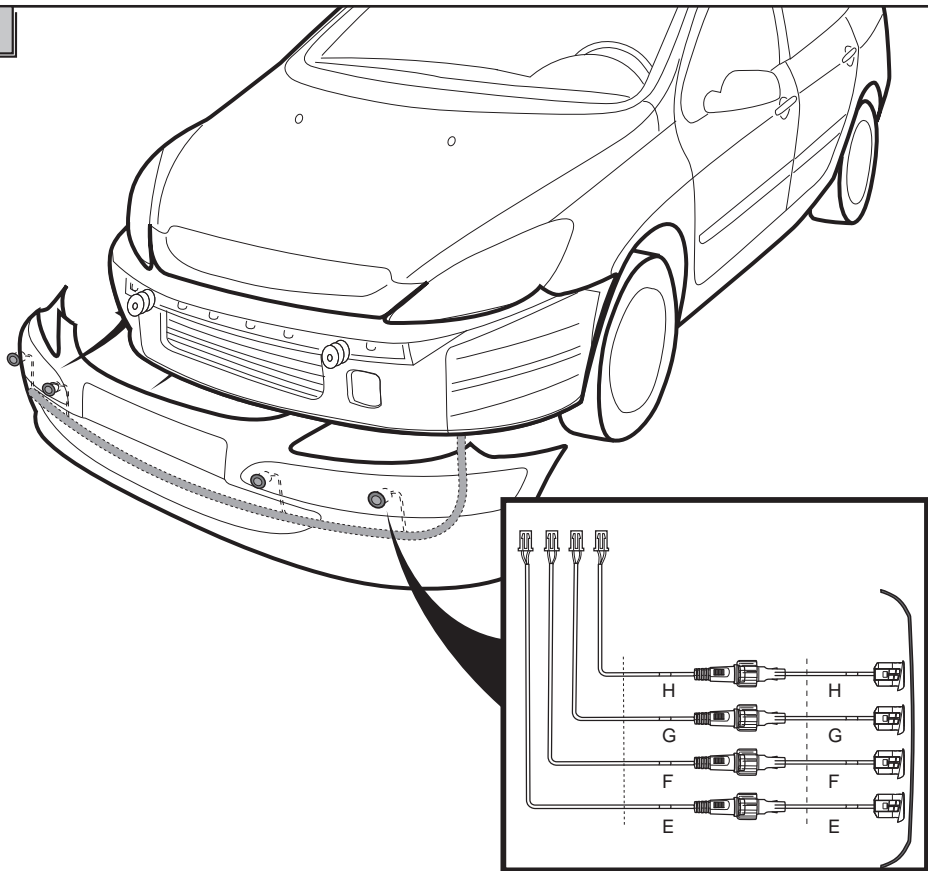

## Buzzer installation

A

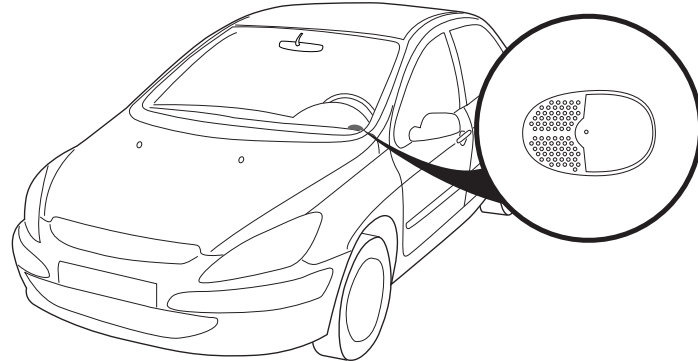

B

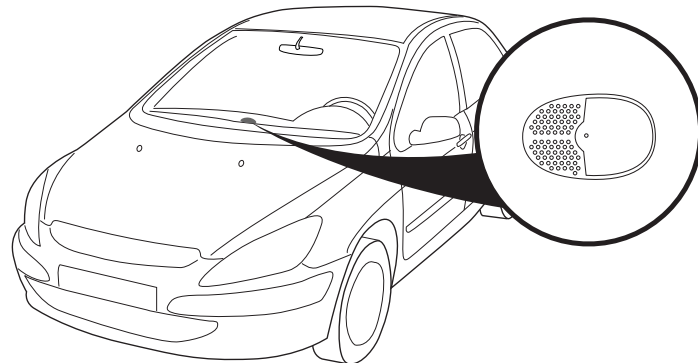

The above are the recommended buzzer installation locations.

## Function test after installation

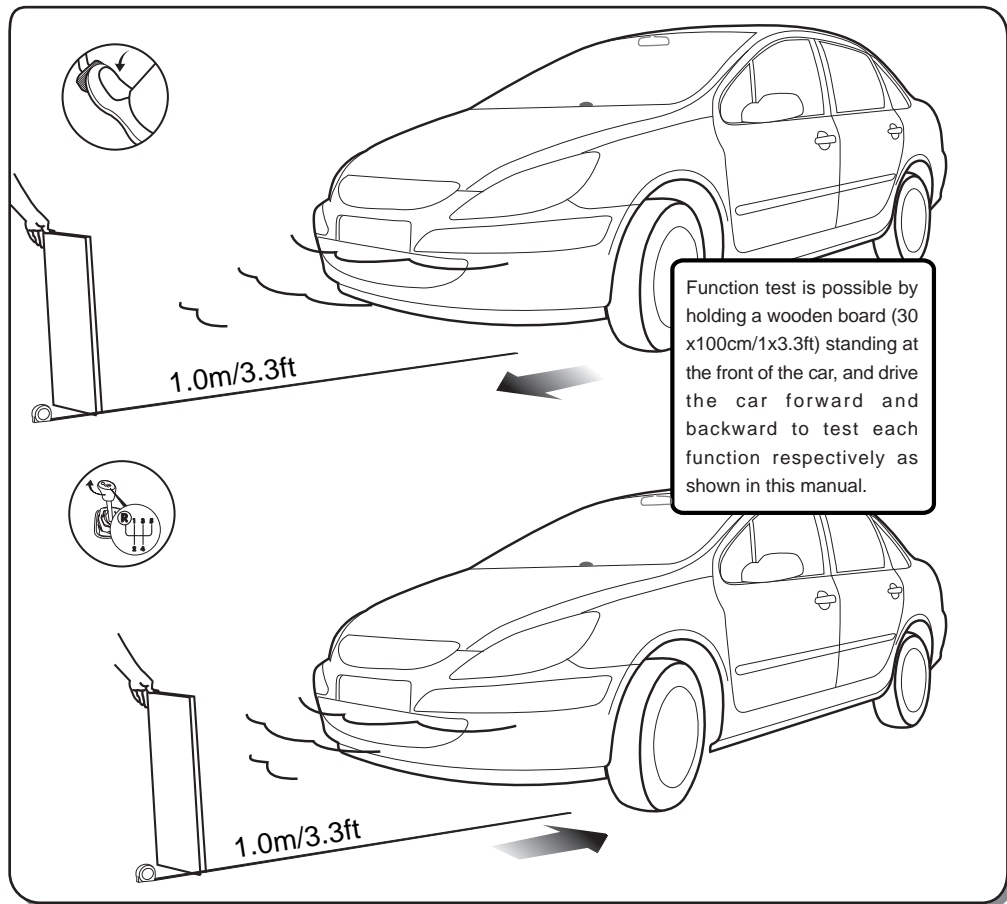

## Installation diagram

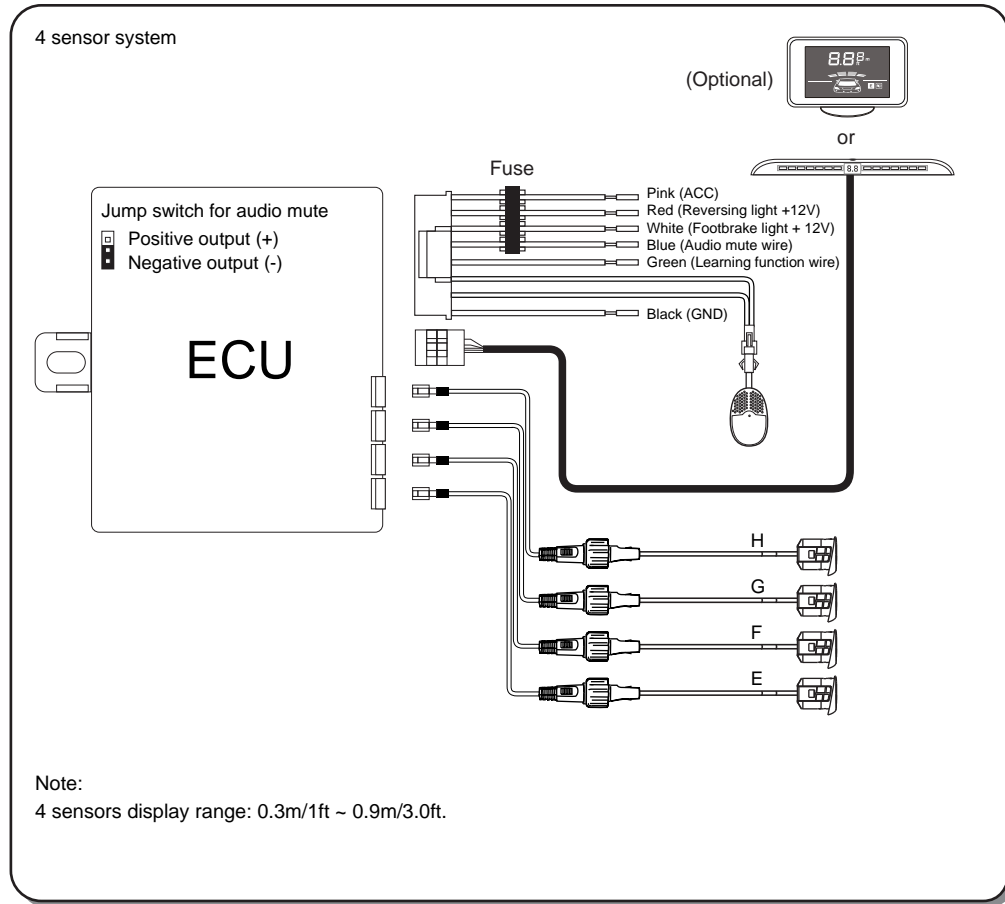

2 sensor system

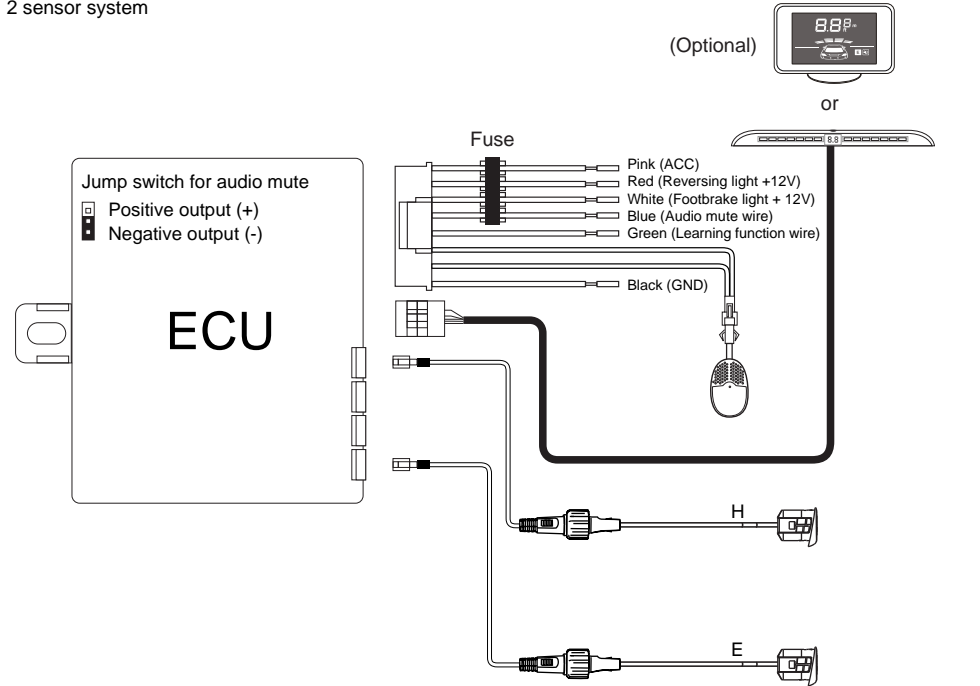

Note:

E & H sensor display range: 0.3m/1ft ~ 0.8m/2.6ft.

2 sensor system

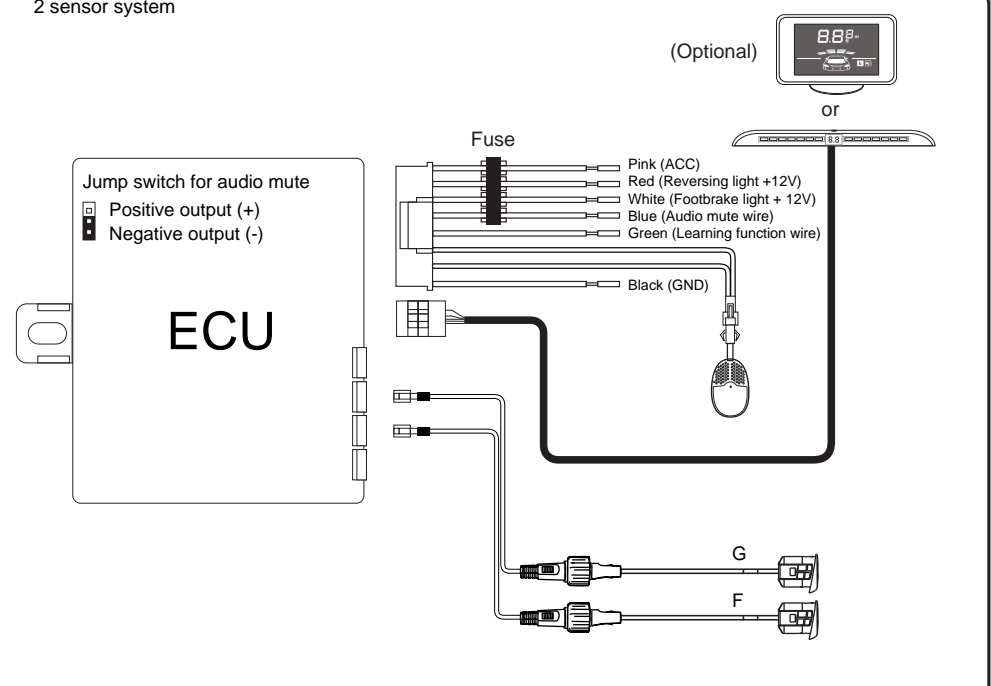

Note:

G & F sensor display range: 0.3m/1ft ~ 0.9m/3.0ft.

## Troubleshooting

After installation, the system doesn't work

- a) Are all wires connected properly?
- b) Is the vehicle's ignition ON?
- c) Is the footbrake pressed?

Damaged sensor detected

- a) Are all sensors plugged into the ECU correctly and tightly?
- b) Is the sensor wire broken?
- c) Is the sensor covered by mud or snow?
- d) Is the sensor damaged?

False warning

- a) Are all sensors plugged into the ECU in the correct position tightly?
- b) Does any sensor detect the ground?

If the problem persists, please follow these steps

- a) For consumers: contact your dealer or nearby service centre.
- b) For installer or dealer:
  - 1) Replace the ECU and recheck the system.
  - 2) Test the sensors with certified ECU by using a flat wooden board.
  - 3) Plug the certified sensors into the ECU and recheck.
  - 4) Email your question to us and we will reply ASAP.

## Warranty terms

The unit is warranted for a limited period of time from the date of purchase. In the unlikely event of a defect arising in this product when used in accordance with the manufacturer's instructions, the parts would be repaired or replaced free of charge.

- a) It is required to show warranty card when making any warranty claims.
- b) The model and the unit's serial number must be the same as the information on the warranty card.

This warranty is non-transferable and is automatically void if

- a) The original purchaser has not completed the warranty card.
- b) The unit's serial number is defaced, missing or altered.
- c) The unit has been modified or used in a manner contrary to its intended purpose.
- d) The unit has been damaged by accident, unreasonable use, neglect, improper installation or service.

The warranty does not cover

- a) Damage caused by incorrect or poor installation problems which may be caused by anomalies in the vehicle's electrical system or originating from the environment in which the system is operated.

- b) Damage to the system caused by accident or improper use in any manner whatsoever not the fault, including but not limited to damage by water or as a result of excess voltage applied to the system or if misused or repaired or altered in any way other than by or its authorized agent.
- c) False information displayed in the panel of the dash board that is caused by car with CAN bus system.

## Warranty card

### Dear user:

Thank you for choosing this product. Please fill the form below and retain it.

### User's information:

User:

Tel:

Vehicle license No.:

Product model No.:

Serial No.:

Date of installation:

Name of the retailer:

Signed by distributor: